

RebarCap

Product Data Sheet

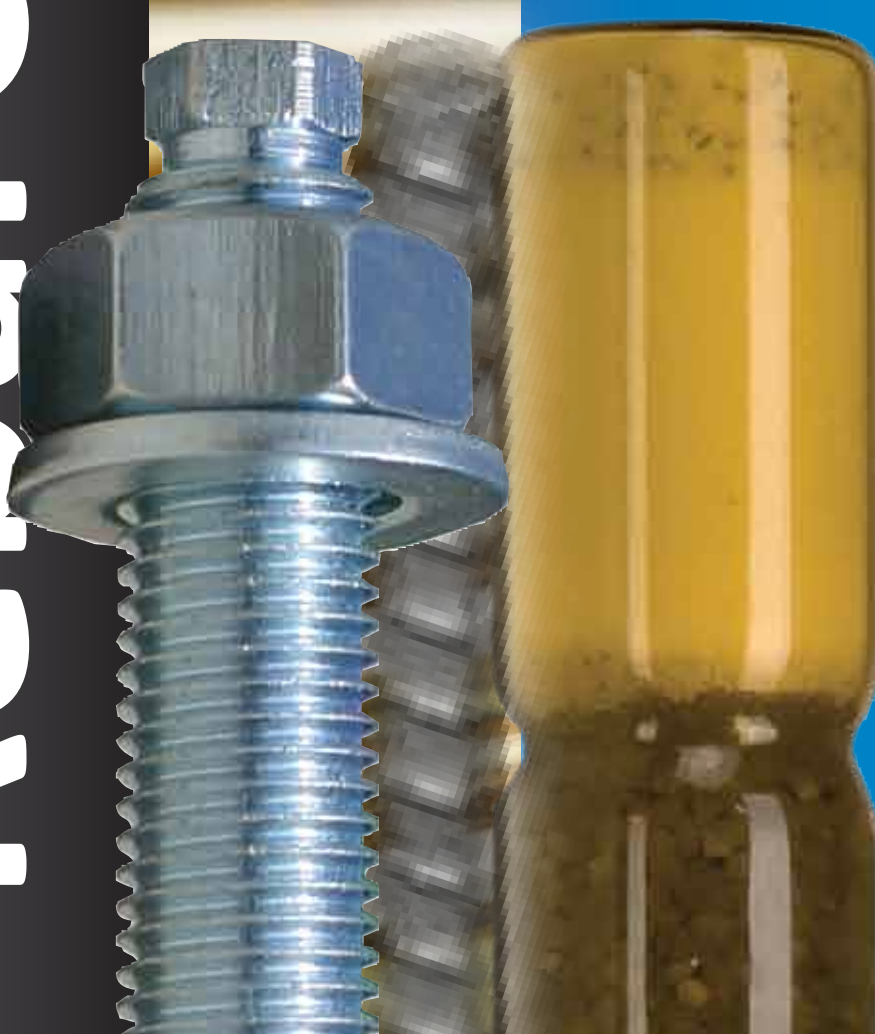

CCS

**CHEMFIX
CAPSULE SYSTEMS**

**Hammer Capsule Data for
Studs & Rebars.**

CHEMFIX

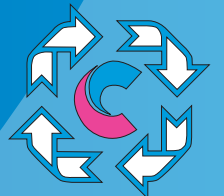

Total Service

Specification Data for HammerCap Anchors using Threaded Rods.

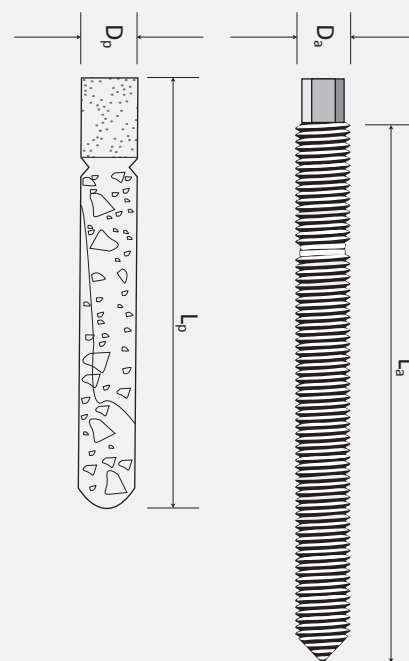
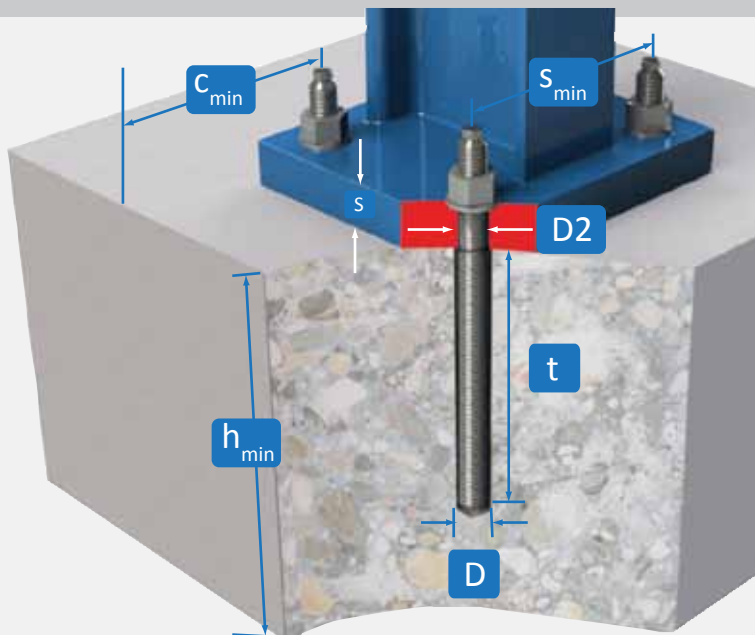

Product Dimensions

Da (mm)	L _s (mm) (t1)	L _s (mm) (t2)	D _p (mm)	L _p (mm)	V _p cc
M8	110	190	9	80	4.0
M10	140	240	11	90	6.4
M12	170	290	13	110	11.3
M16	225	385	17	125	23.1
M20	290	490	22	175	53.0
M24	330	570	24	210	76.0
M30	400	700	33	265	191.0

Installation Dimensions

Da (mm)	D (mm)	t1 (mm)	t2 (mm)	D2 (mm)	S (mm)	No. Capsules (t1)	No. Capsules (t2)	Nm
M8	10	80	160	12	18	1	2	6
M10	12	100	200	14	25	1	2	12
M12	14	120	240	16	34	1	2	20
M16	18	160	320	20	45	1	2	45
M20	25	200	400	25	55	1	2	100
M24	28	240	480	28	55	1	2	150
M30	35	300	600	35	55	1	2	300

Ultimate Tensile Loads For HammerCap Anchors (Concrete >B25) (kN)

Size	M8	M10	M12	M16	M20	M24	M30
5.8	18	27	38	66	114	154	240
8.8	18	27	38	66	114	154	240
V4A	18	27	38	66	114	154	240

Ultimate Shear Loads For HammerCap Anchors (Concrete >B25) (kN)

Size	M8	M10	M12	M16	M20	M24	M30
5.8	11	17	25	47	73	105	168
8.8	17	27	40	75	118	170	268
V4A	15	24	35	65	102	105	168

Recommended Safety Factors

- Heavy reinforced concrete for static loads in the compressive zone - 2.5 - 3
- Concrete subject to vibratory loads - 3.5 - 4
- Polluted areas - 3.5 - 4
- The tensile zone of the concrete - 3.5 - 4
- Severe weather conditions: cold-wet-warm-cold - 4 - 5
- Underwater installation - 4 - 5
- Earthquake areas - 5 - 6

Recommended Center to Center Distances (Concrete >B25)

Size	M8	M10	M12	M16	M20	M24	M30
mm	200	220	270	310	420	520	700

Recommended Center to Edge Distances (Concrete >B25)

Size	M8	M10	M12	M16	M20	M24	M30
mm	100	110	135	155	210	260	350

*Load Reduction Factors (Ka) for
reduced center to center spacing*

Centre to Centre (cm)	Size						
	M8	M10	M12	M16	M20	M24	M30
70.00							1.00
68.00							0.99
66.00							0.97
64.00							0.96
62.00							0.94
60.00							0.93
58.00							0.91
56.00							0.90
54.00							0.89
52.00					1.00	0.87	
50.00					0.98	0.86	
47.00					0.95	0.84	
45.00					0.93	0.82	
44.00					0.92	0.81	
42.00				1.00	0.90	0.80	
40.00				0.98	0.88	0.79	
38.00				0.95	0.87	0.77	
36.00				0.93	0.85	0.76	
34.00				0.90	0.83	0.74	
32.80				0.89	0.82	0.73	
32.00				0.88	0.81	0.73	
31.00				1.00	0.87	0.80	0.72
30.00				0.98	0.86	0.79	0.71
28.00				0.95	0.83	0.77	0.70
27.00			1.00	0.94	0.82	0.76	
26.00			0.98	0.92	0.81	0.75	
24.80			0.96	0.90	0.80	0.74	
24.00			0.94	0.89	0.79	0.73	
22.00		1.00	0.91	0.85	0.76	0.71	
20.80		0.97	0.89	0.84	0.75	0.70	
20.00	1.00	0.95	0.87	0.82	0.74		
18.80	0.97	0.93	0.85	0.80	0.72		
18.00	0.95	0.91	0.83	0.79	0.71		
16.80	0.92	0.88	0.81	0.77	0.70		
16.00	0.90	0.86	0.80	0.76			
14.00	0.85	0.82	0.76	0.73			
12.40	0.81	0.78	0.73	0.70			
12.00	0.80	0.77	0.72				
10.80	0.77	0.75	0.70				
10.00	0.75	0.73					
8.80	0.72	0.70					
8.00	0.70						

*Load Reduction Factors (Ka) for
reduced center to edge spacing*

Centre to Edge (cm)	Size						
	M8	M10	M12	M16	M20	M24	M30
35.00							1.00
34.00							0.97
33.00							0.94
32.00							0.91
31.00							0.89
30.00							0.86
29.00							0.83
28.00							0.80
27.00							0.77
26.00						1.00	0.74
25.00						0.96	0.71
24.00						0.92	0.69
23.50						0.90	0.67
22.00						0.85	0.63
21.00					1.00	0.81	0.60
20.00					0.95	0.77	0.57
19.00					0.90	0.73	0.54
18.00					0.86	0.69	0.51
17.00					0.81	0.65	0.49
16.40					0.78	0.63	0.47
16.00					0.76	0.62	0.46
15.50				1.00	0.74	0.60	0.44
15.00				0.97	0.71	0.58	0.43
14.00				0.90	0.67	0.54	0.40
13.50			1.00	0.87	0.64	0.52	
13.00			0.96	0.84	0.62	0.50	
12.40			0.92	0.80	0.59	0.48	
12.00			0.89	0.77	0.57	0.46	
11.00		1.00	0.81	0.71	0.52	0.42	
10.40		0.95	0.77	0.67	0.50	0.40	
10.00	1.00	0.91	0.74	0.65	0.48		
9.40	0.94	0.85	0.70	0.61	0.45		
9.00	0.90	0.82	0.67	0.58	0.43		
8.40	0.84	0.76	0.62	0.54	0.40		
8.00	0.80	0.73	0.59	0.52			
7.00	0.70	0.64	0.52	0.45			
6.20	0.62	0.56	0.46	0.40			
6.00	0.60	0.55	0.44				
5.40	0.54	0.49	0.40				
5.00	0.50	0.45					
4.40	0.44	0.40					
4.00	0.40						

Installation Procedure for Hammer Capsules with Threaded Rods

- Drill hole either with an electric rotary hammer or a diamond drilling machine.
- In reinforced concrete the use of a diamond drilling machine is recommended.
- Clean anchor hole thoroughly by using a brush and compressed air or water.
- Before inserting the hammer capsule into the hole, check the viscosity of the resin. At lukewarm temperature, it should run easily inside the capsule.
- Always take care to note the arrow direction on the capsule before inserting into the hole. To ensure that the capsule is inserted correctly, always have the arrow pointing towards the hole as you insert the capsule.
- Clean anchor rod before inserting into the hole. Anchor rod should be free of any grease, corrosion or oils.
- Mark the anchor rod with the correct embedment depth. Installation of the rod may be executed manually, using a handheld hammer or mechanically using an electric or pneumatic percussion tool providing sufficient power to mix the components completely. (!! Always wear safety goggles when installing anchors).
- Observe curing times. The installed anchor may not be disturbed or loaded before the specified curing time.

Curing Times for Dry Hole Installation

Concrete Temperature °C	Curing Time
> 20	1 hrs
10 - 20	2 hrs
0 - 10	5 hrs
-5 - 0	10 hrs

Curing Times for Damp Hole Installation

Concrete Temperature °C	Curing Time
> 20	2 hrs
10 - 20	4 hrs
0 - 10	10 hrs

In-Situ Test Procedures

- We recommend to test 3% of the anchors with a minimum of 2 anchors per dimension. The proof load may be calculated as:

$$\text{Proof Load} = \frac{1.3 \times \text{Ultimate Load} \times \text{Reduction Factor}}{\text{Safety Factor}}$$

- Slippage should not exceed 0.2mm. If one anchor fails to meet the proof specifications, check 25% of all the anchors in that area.

Specification Data for Hammer Capsules Anchors using Rebar.

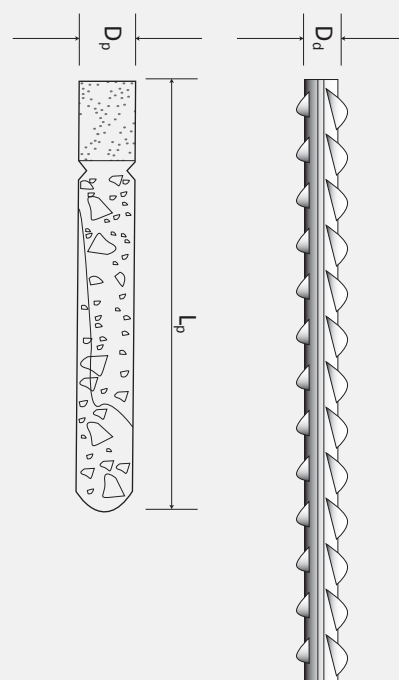
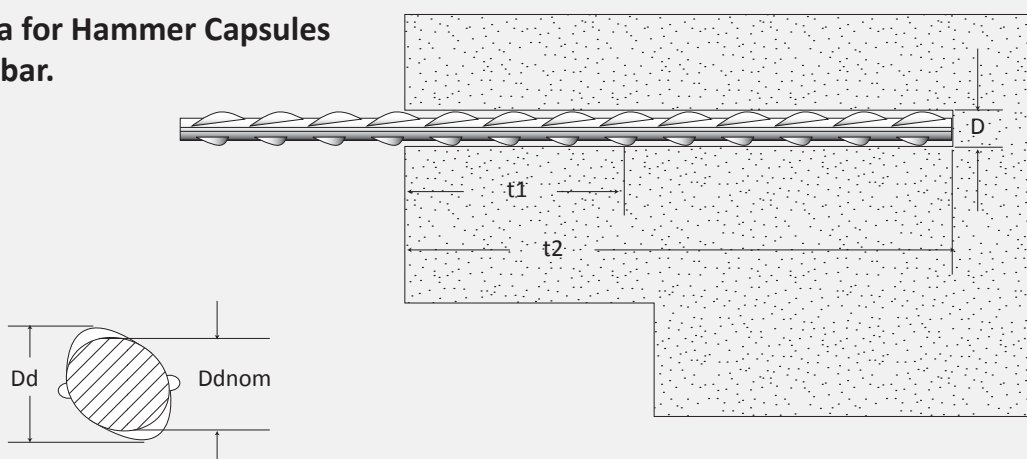

Product Dimensions

Ddnom (mm)	Dd (mm)	Dp (mm)	Lp (mm)	Vp (cc)
8	9.5	9	80	4.0
10	11.5	11	90	6.4
12	13.9	13	110	11.3
14	16.0	17	125	23.1
16	18.7	17	125	23.1
20	23.4	22	175	53.0
25	29.2	24	210	76.0
32	37.4	33	265	191.0

Installation Dimensions

Ddnom (mm)	Dd (mm)	t1 (mm)	t2 (mm)	No. Of Capsules t1	No. Of Capsules t2
8	10	80	160	1	2
10	13	100	200	1	2
12	15	120	240	1	2
14	18	140	280	1	2
16	20	160	320	1	2
20	25	200	400	1	2
25	30	250	500	1	2
32	38	320	640	1	2

Load Bearing Capacity

The load bearing capacity of embedded dowels depends on:

- embedment depth.
- concrete quality.
- steel quality of the dowel.
- bond strength.

It is common engineering practice to use between 15 and 20 times the nominal dowel diameter (D_{nom}) as embedment depth.

Calculation Procedure for the Ultimate Bond Strength:

For embedment depths between 10 and 20 times the nominal dowel diameter (D_{nom}), the ultimate bond strength for rebar dowel installations in concrete B25 or better with hammer capsules may be calculated using the following equation:

$$\text{Bond Strength (kN)} = 0.023 \times \text{drill diameter (mm)} \times \text{embedment depth (mm)}$$

Recommended Safety Factors

- | | | |
|--|---|---------|
| • Heavy reinforced concrete for static loads in the compressive zone | - | 2.5 - 3 |
| • Concrete subject to vibratory loads | - | 3.5 - 4 |
| • Polluted areas | - | 3.5 - 4 |
| • The tensile zone of the concrete | - | 3.5 - 4 |
| • Severe weather conditions: cold-wet-warm-cold | - | 4 - 5 |
| • Underwater installation | - | 4 - 5 |
| • Earthquake areas | - | 5 - 6 |

Installation Procedure for Hammer Capsules with Rebar Doweling

- Drill hole either with an electric rotary hammer or a diamond drilling machine.
- In reinforced concrete the use of a diamond drilling machine is recommended.
- Clean anchor hole thoroughly by using a brush and compressed air or water.
- Before inserting the hammer capsule into the hole, check the viscosity of the resin. At lukewarm temperature, it should run easily inside the capsule.
- Always take care to note the arrow direction on the capsule before inserting into the hole. To ensure that the capsule is inserted correctly, always have the arrow pointing towards the hole as you insert the capsule.
- Clean the rebar dowel before inserting into the hole. The dowel should be free of any grease, corrosion or oils.
- Mark the rebar dowel with the correct embedment depth. Installation of the rod may be executed manually, using a handheld hammer or mechanically using an electric or pneumatic percussion tool providing sufficient power to mix the components completely. (!! Always wear safety goggles when installing anchors).
- Observe curing times. The installed dowel may not be disturbed or loaded before the specified curing time.

Curing Times for Dry Hole Installation

Concrete Temperature °C	Curing Time
> 20	1 hrs
10 - 20	2 hrs
0 - 10	5 hrs
-5 - 0	10 hrs

Curing Times for Damp Hole Installation

Concrete Temperature °C	Curing Time
> 20	2 hrs
10 - 20	4 hrs
0 - 10	10 hrs

In-Situ Test Procedures

- We recommend to test 3% of the anchors with a minimum of 2 anchors per dimension. The proof load may be calculated as:

$$\text{Proof Load} = \frac{1.3 \times \text{Ultimate Load} \times \text{Reduction Factor}}{\text{Safety Factor}}$$

- Slippage should not exceed 0.2mm. If one anchor fails to meet the proof specifications, check 25% of all the anchors in that area.

STORAGE / SHELF LIFE	IMPORTANT
<p>This product should be stored between +5°C & +25°C.</p> <p>The Shelf life of the product is 24 months from the manufacture date.</p>	<p>The information and data given is based on our own experience, research and testing and is believed to be reliable and accurate. However, as Chemfix Products cannot know the varied uses to which its products may be applied, or the methods of application used, no warranty as to the fitness or suitability of its products is given or implied. It is the users responsibility to determine suitability of use. For further information please contact our Technical Department.</p>